

**Safety  
in which  
you can trust**





SKUDO



OSAS



USAS



OPAS



**Special Springs has been for years an innovator in the market. Its core competencies being safety and durability of products. Thanks to Special Springs' know-how and R&D it has developed the new and improved Lifeplus Concept, which includes a series of safety devices meant to increase and improve safety and life of gas cylinders: OSAS, USAS, OPAS, SKUDO. At the base of these, as for all Special Springs products, are continuous researches and developments, the use of the latest technologies, quality and safety controls, all in full compliance with regulations and focused on guaranteeing you superior quality, durability, reliability. Remember: not all nitrogen cylinders are the same.**

## **Index**

OSAS	p.04
USAS	p.06
OPAS	p.08
SKUDO	p.09
Reliability	p.10
Training and support	p.11



# OSAS

## Over Stroke Active Safety

### What is it?

OSAS are 3 unique Special Springs safety solution devices, which exhaust pressure in a controlled and complete mode, when working stroke exceeds the nominal value.

### How is it made?

#### 1. Body - bush design

OSAS is the combination of an outward extension of the bush with discontinuity groove on the body-bush sealing wall. OSAS self activates without deforming the body of the cylinder, further improving safety for users.

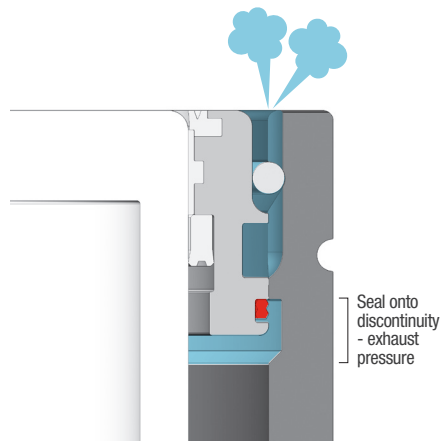
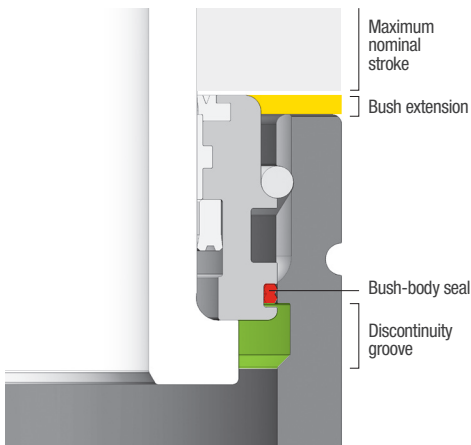
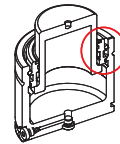

### OSAS' Benefits

- Exhausts pressure in a controlled and complete mode, when the cylinder has been overstroked.
- Reduces the risk of tool damage or injury due to ejection of parts under pressure.
- Self activates automatically regardless of users' intervention.
- Does not increase the cost of the cylinders.

## 2. Body - bottom plate design

OSAS is the combination of a deformable body skirt with discontinuity groove on the body-bottom plate sealing wall. OSAS self activates without causing structural damages to the cylinder, further improving safety for users.

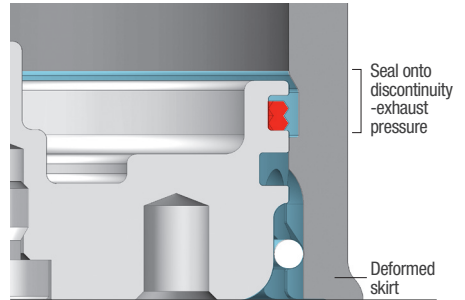
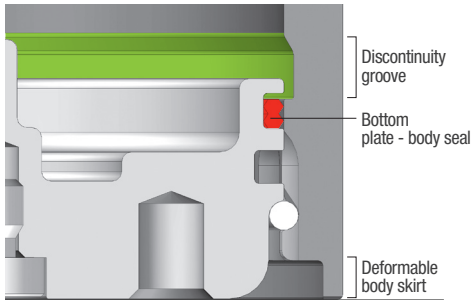
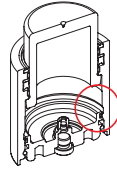

## 3. Body - piston design

OSAS are discontinuity grooves on the body-piston sealing wall. OSAS self activates without deforming the body of the cylinder, further improving safety for users.

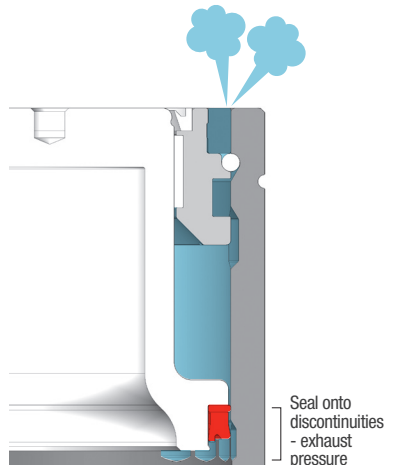
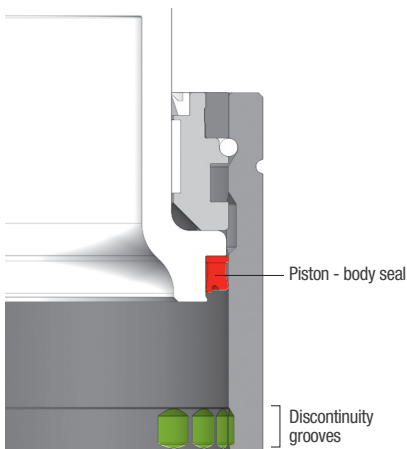
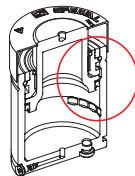



# USAS

## Uncontrolled Speed Active Safety

### USAS' Benefits

- Exhausts pressure in a controlled and complete manner when the cylinder has been stressed by uncontrolled returns.
- Reduces the risk of tool damage or injury due to ejection of parts under pressure.
- Self activates automatically regardless of users' intervention.
- Does not increase the cost of the cylinders.

### What is it?

USAS are 3 unique Special Springs safety solution devices, which exhaust pressure in a controlled and complete mode, without ejection of parts when the cylinder has been stressed by uncontrolled return of the piston rod.

This is typically caused by the seizure and jam of the die plates or stamped parts that, subjected to pressure thrust, are released in an uncontrolled manner.

### How is it made?

#### 1. Body - bush design

USAS is the combination of a deformable part of the bushing in contact with the retaining C-ring and the discontinuities on the wall of contact of the body-bush seal.

USAS self activates without causing structural damages to the cylinder, further improving safety for users.

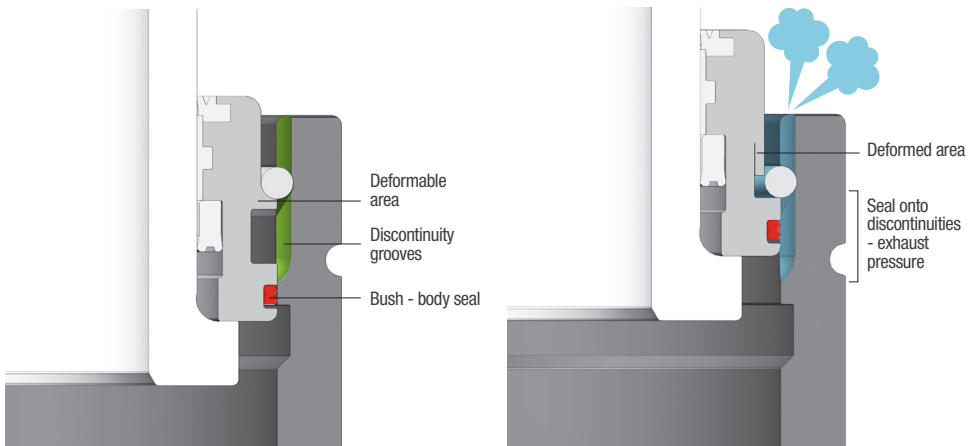
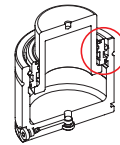

## 2. Body - bottom plate design

USAS is the combination of a deformable part of the bottom plate in contact with the retaining C-ring and the discontinuities on the wall of contact of the body-bottom plate.

USAS self activates without causing structural damages to the cylinder, further improving safety for users.

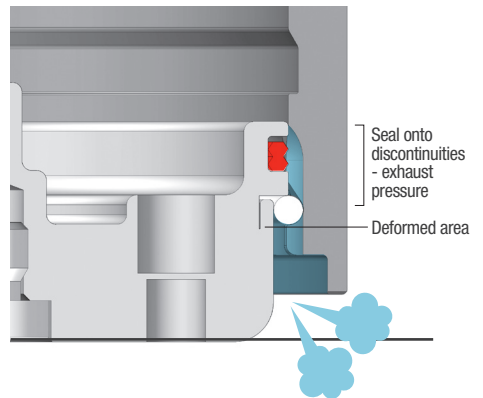
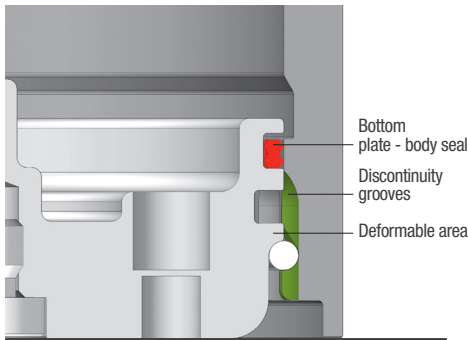
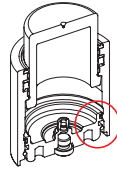

## 3. Body - piston design

USAS is the combination of a deformable part of the bushing in contact with the retaining C-ring and the discontinuities on the wall of contact of the piston seal. USAS self activates without causing structural damages to the cylinder, further improving safety for users.

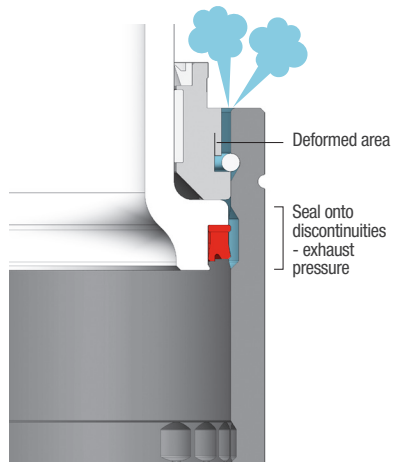
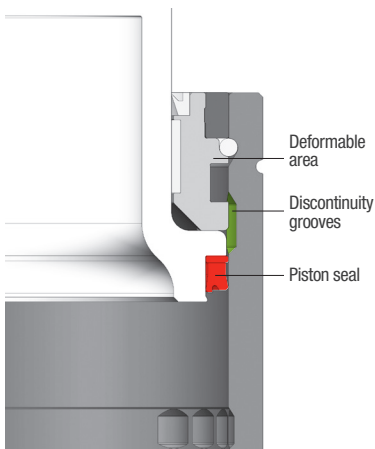
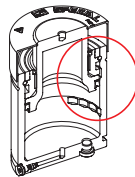



# OPAS

## Over Pressure Active Safety

### OPAS' Benefits

- Exhausts the pressure in a controlled and complete manner when it exceeds the maximum value allowed.
- Reduces the risk of tool damage or injury due to ejection of parts under pressure.
- Self activates automatically regardless of users' intervention.
- Does not increase the cost of the cylinders.

### What is it?

OPAS are 2 unique Special Springs safety solution devices, built or mounted on the bottom of the cylinders, which exhaust pressure in a controlled and complete manner when the latter exceeds maximum allowed.

This is typically caused when stamping contaminants get into the gas room reducing its volume.

### How is it made?

OPAS is either the combination of a rupture septum or a rupture plug positioned in the bottom of the cylinders, with an exhaust milling on the bottom contact surface.

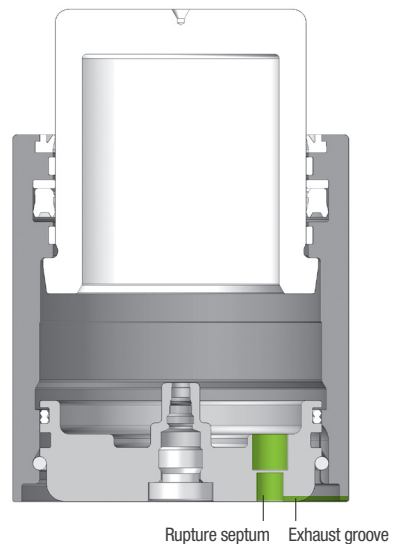
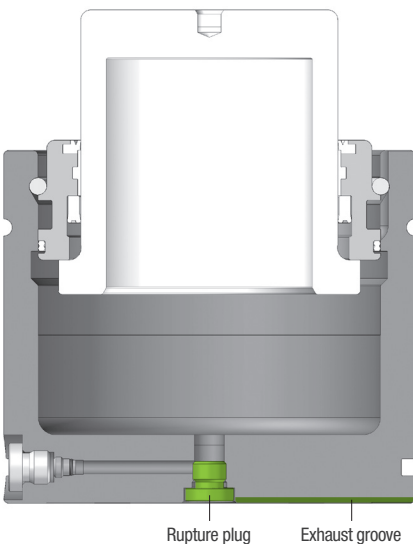
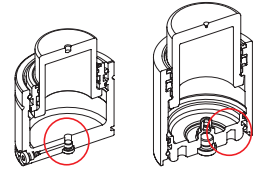



# SKUDO

## Active Protection from Contaminants

### SKUDO' Benefits

- Eliminates damages to guiding and sealing components caused by contaminants.
- Significantly increases the life of cylinders used in severe working environments.
- Does not alter the height of the cylinder.
- Does not wear out.
- Is available for all Special Springs cylinders.

### What is it?

SKUDO is a unique Special Springs solution, which protects the sealing and guiding components of the cylinder from liquid and solid contaminants and which eliminates situations of over pressure.

### How is it made?

SKUDO is a protective plastic cap securely fixed on the top of the rod, with no alteration to the contact surface of the rod with the plate.

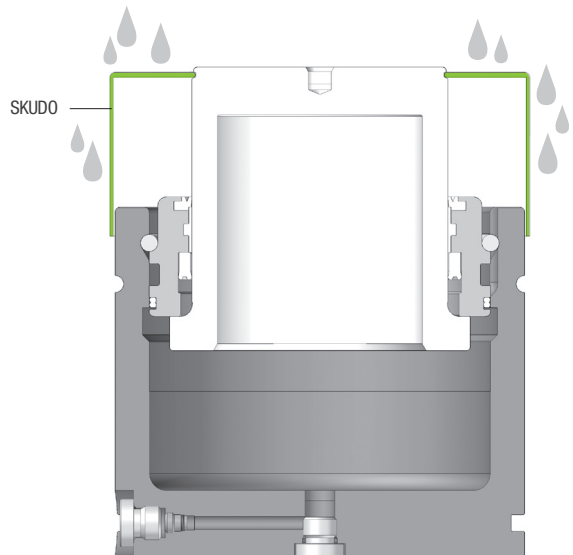
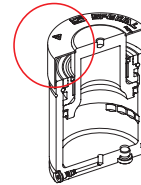

# RELIABILITY

## PED 97/23/EC

The design and manufacturing of Special Springs' gas cylinders are in full compliance with the European regulations for high pressure vessels, in accordance with directive PED 97/23/EC.



0496

### Benefits

- Greater assurance for customers of safer products and components.

## FEM - CAE

All Special Springs products are developed and validated via the use of the most advanced FEM (finite element method) and CAE (computer aided engineering) analysis systems

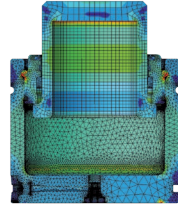

### Benefits

- Greater assurance for customers of safer products and components.

## STRUCTURE OF A GAS CYLINDER

All structural components of Special Springs' gas springs are designed and built to withstand a minimum of 2,000,000 complete cycles at maximum pressure, temperature and for all types of fixings.

### Benefits

- Greater assurance for customers of safer products and components.

> 2.000.000

## DYNAMIC TESTS

Endurance and structural crash tests, with heavy and dangerous working conditions, are essential and continuously carried out on finished products, in order to attain complete validation of design and technical solutions.

To develop the active safety features, Special Springs has designed and built special custom machines and equipment, suitable to test the efficiency of the features at different working conditions.

### Benefits

- Greater assurance for customers of tested safer products and components.

# TRAINING AND SUPPORT

## KNOWLEDGE

Knowledge is an essential element for successful daily actions; the more we know, the better we perform.

This concept has always been one of Special Springs' core values. For many years the company has been committed to increase knowledge of products along with their characteristics and their best utilisations techniques, through theoretical and practical training.

### Benefits

- Increased knowledge of users, in regards to the real benefits given by Special Springs gas cylinders. (i.e.: reduction of tool damages and injury)
- Increased knowledge of users on how to appropriately use the products, hence benefit from cost and production efficiency.
- Increased knowledge of users on the importance of our gas cylinders safety features.

## TECHNICAL SUPPORT

Special Springs has always been committed to provide technical support for users; we provide a thorough multilingual instruction sheet with each cylinder or component.

### Benefits

- Increased confidence of user in utilising gas cylinders.
- Increased safety with reduction of tool damages and injuries due to inappropriate usage.
- Cost savings with increased production efficiency.



## 2D - 3D CAD FILES

[www.partserver.com](http://www.partserver.com)

